

Име. № _____
 Подпись и дата _____
 зам. Инв. № _____

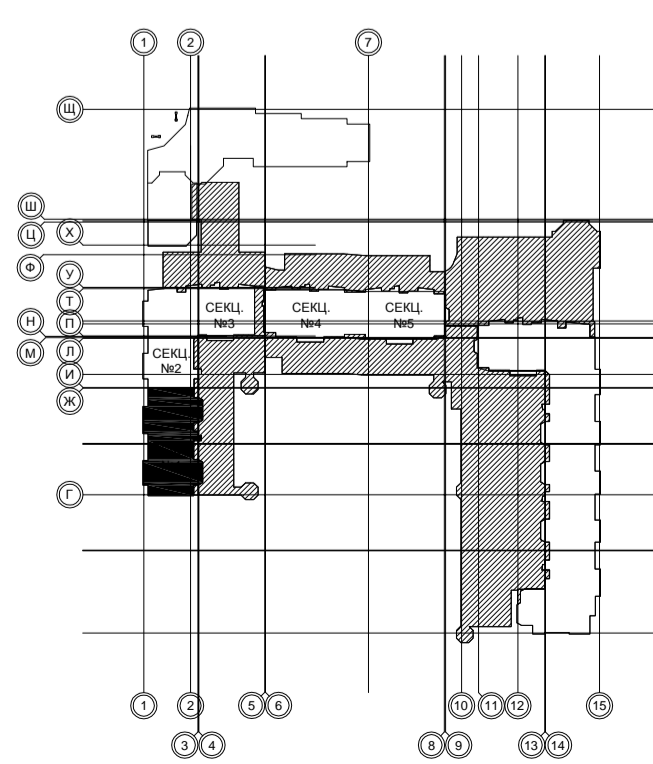

Инв. № _____
 Подпись и дата _____
 зам. Инв. № _____

Секция 1. Схема магистральных трубопроводов

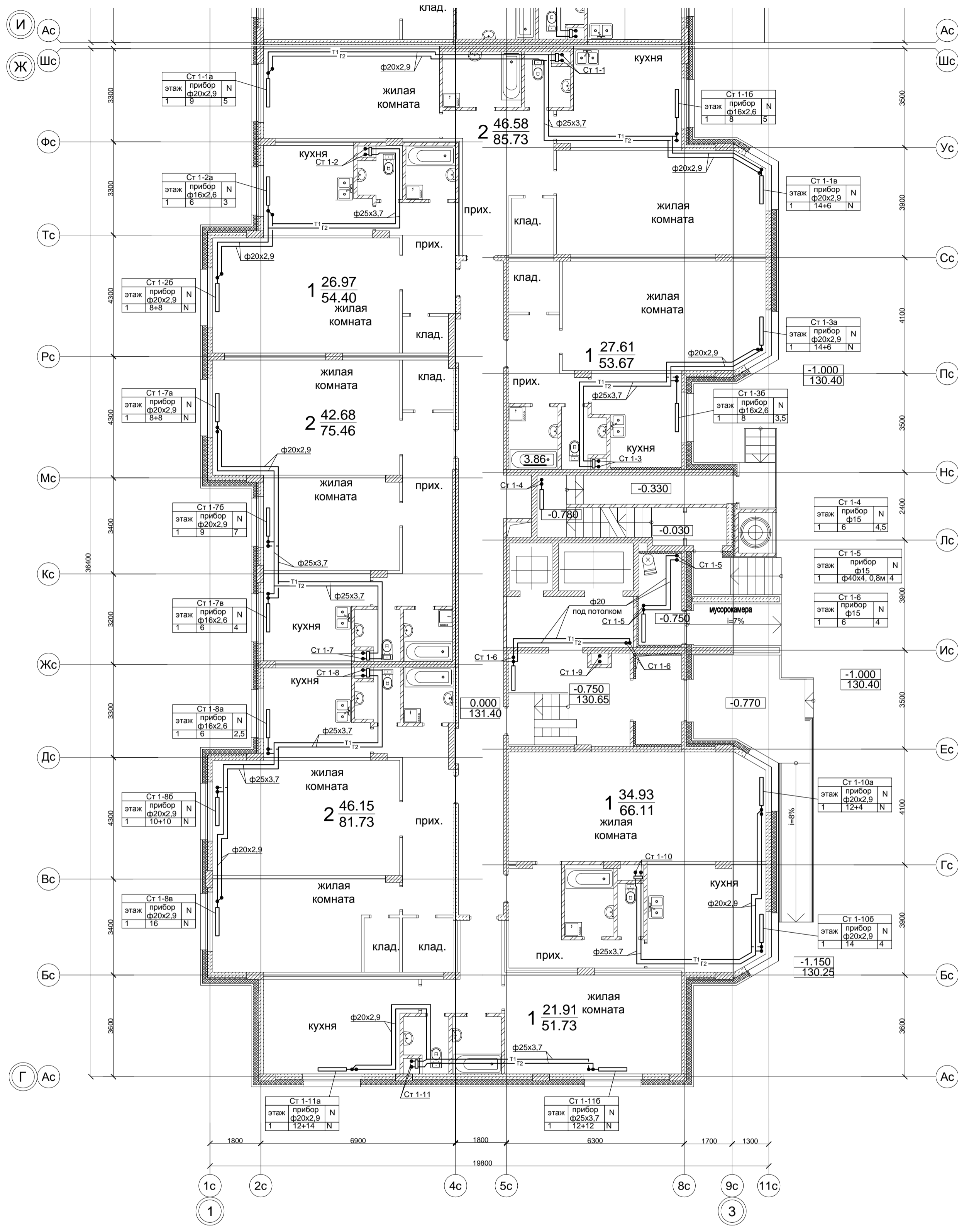
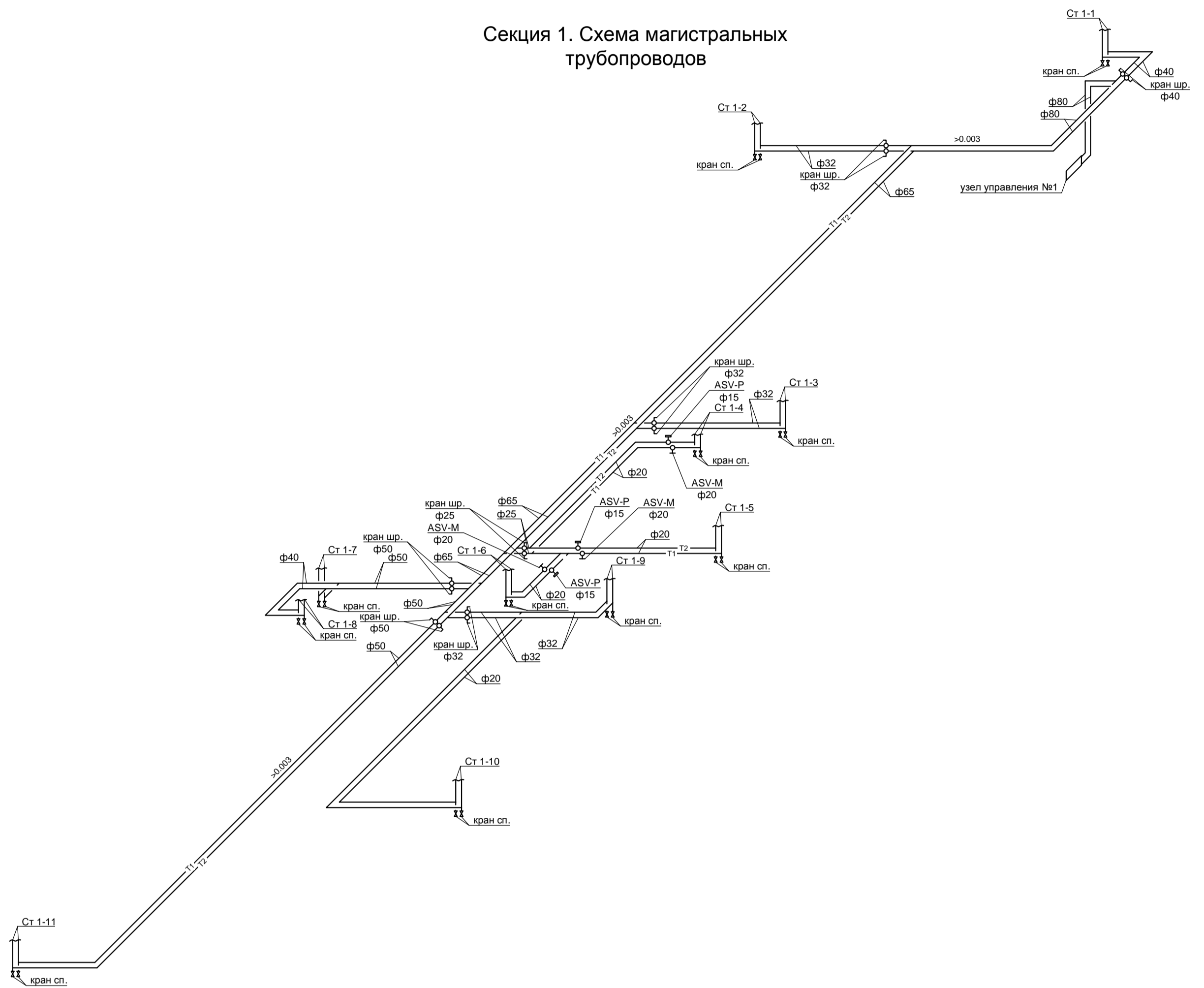

Узел управления 1

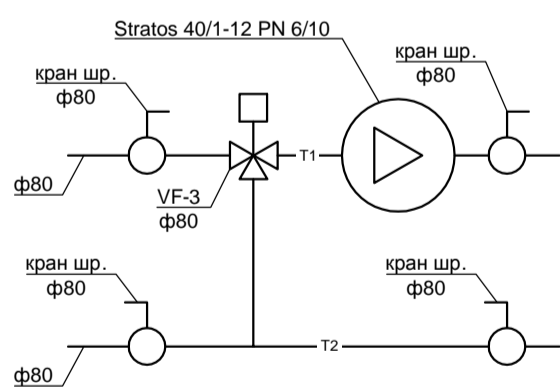

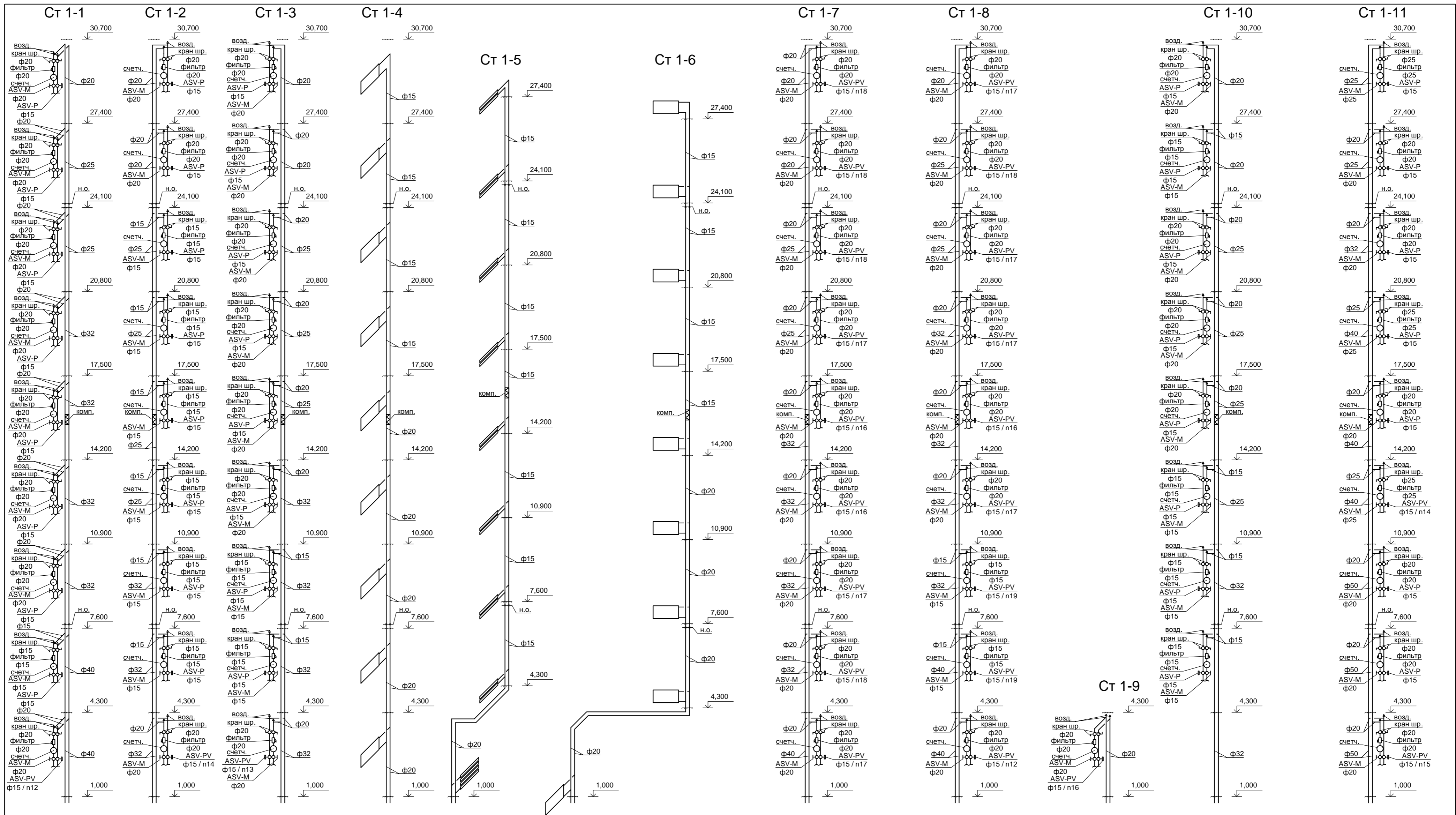

Изм. №	Подпись и дата	зам. Илв. №